

Digital Power Factor Regulator

NV-5/7



features



- True RMS Measurement
- LED Step Indication
- Automatic / Manual Step Operation
- Automatic or Manual C.T. Polarity
- Automatic C/K Detection or User Preset
- Automatic or User Preset Switching Sequence (rotational for same size grouping)
- Operation from 1% Load
- Viewable Parameters:
V, I, Cos φ, PF, Hz, W, Var, THD-V, THD-I, Harmonics Spectrum up to 15th order for V & I (secondary values for I, W, Var)
- Individual Capacitor Step Info:
- Hour run (accumulative)
- Usage count (accumulative)
- Secondary 1-phase Var value (present)
- Programmable Over Voltage & THD-V alarm
- Alarm Information:
- Under / Over Compensate
- Under / Over Voltage
- Overload, THD-V Limit High
- User selectable capacitor protection for Over voltage & THD-V
- Selectable contact for Signal Alarm Output or Exhaust Fan Output
- Extrenal Plug-in Module for:
A-01s / A-01sp (RS-485 Modbus RTU) isolated type
- Software Lock to prevent unauthorized modification of parameters
- Complies with:
IEC 61000-6-2 / 6-4 Standards
IEC 60255-27-Clause 10.6.4.2 / 4.3

technical data

Aux Power Supply

AC range : 85 ~ 275 VAC, 45 ~ 65 Hz
Consumption : < 3 VA

Power Measurement

Accuracy (W, Var, Cos φ, PF) : ± 1.0%

Current Measurement

AC Input range : 0,01 ~ 6,50 A
Accuracy : ± 1,0 %
CT range : .. / 5A
Burden : < 0,1 VA at 5A

Voltage Measurement

AC Input range : according to Aux Power Supply
Accuracy : ± 1,0 %

Frequency Measurement

Range: : 45 ~ 65 Hz
Accuracy : ± 0,1 %

LEDs Indication

Individual Steps, Aux Fan, x1000, A, PF, V, Hz, W, Var, thd, nth Harmonic, Auto/Manual, Cap., Ind.

Mechanical

Output Relay (Individual Steps / Alarm / Fan) Rating : SPST 7A, 250 VAC
Electrical Life : 100,000 operations at rated current
Mechanical Life : 5 x 10⁶ operations
No voltage release : < 40ms
Operating Temp. : -5°C ~ +55°C
Humidity : 56 days at 93%RH, 40°C non-condensing
IP Rating : IP54 (front panel)
Installation : Panel flush mount
Weight : 280 g

parameter setting

- C/K Value** : Auto or 0,01 ~ 0,80 (step of 0,01)
- Target Cos φ** : 0,85 (Ind.) ~ 0,90 (Cap.) (step of 0,01)
- Switching Program** : Auto or P-0 ~ P-7
- Switching Interval** : (t-on) : 1s ~ 250s (step of 1s)
(t-off) : 1s ~ 250s (step of 1s)
- Reconnection Inhibit** : OFF or 5s ~ 900s (step of 5s)
- V> (Over Voltage)** : OFF or 100 V ~ 260 V (step of 1 V)
- thd-V > (%)** : OFF or 3, 4, 5, 6, 7, 8, 10%

selectable switching program sequence

Auto	Automatic
P-0	Linear
P-1	1 : 1 : 1 : 1 : 1
P-2	1 : 2 : 2 : 2 : 2
P-3	1 : 2 : 4 : 4 : 4
P-4	1 : 1 : 2 : 2 : 2
P-5	1 : 1 : 2 : 2 : 4
P-6	1 : 1 : 1 : 2 : 2
P-7	1 : 2 : 4 : 8 : 8

casing dimension

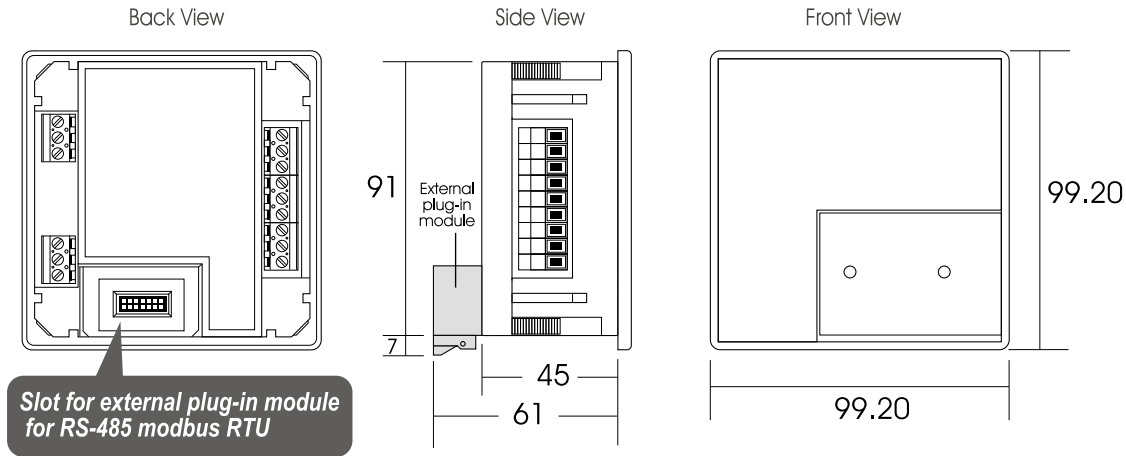

wiring diagram: NV-5/7 (3P4W)

P-n (3P4W)

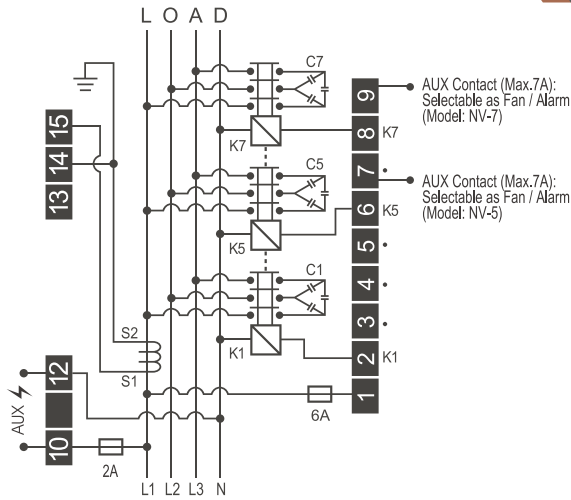

wiring diagram: NV-5/7 (3P3W)

P-P (3P3W)

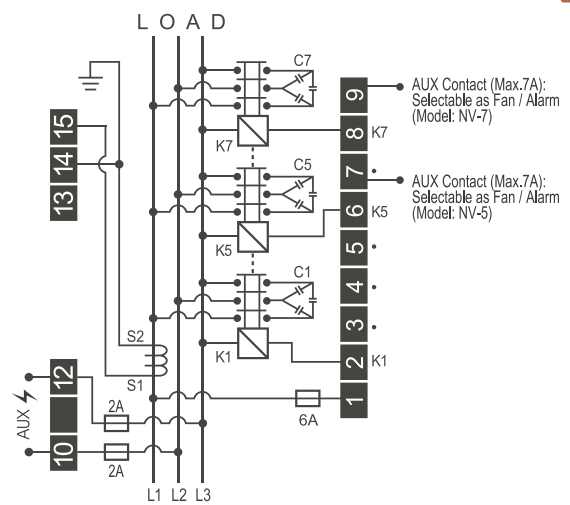

panel cut-out

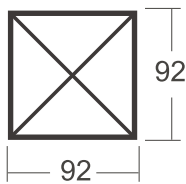

Panel Cut-out : 92 x 92

AUX Power Supply Range	AUX Power Connection	C.T. Phase Connection
85~275 VAC	L1- N (P-n)	L1
45~65 Hz	L2- L3 (P-P)	L1

⚠ WARNING
Do not exceed Aux power supply specification.

ordering information

Model	Description
NV-5	85 ~ 275 VAC (45~65 Hz)
NV-7	85 ~ 275 VAC (45~65 Hz)

Note: All measurement in mm.